

BREAK OUT AREA



## Welcome

Meet and Greet

P. 6-19

SOFT SEATING  
& ZONING

## Lounge

Hang out, group work  
or socialise

P. 20-35

SOFT SEATING

## Impromptu

Touch down, meeting  
or coffee break

P. 36-52

TABLES & CHAIRS  
& CONNECTION

## Pause

Reception, Waiting area  
or power down

P. 54-65

SOFT SEATING  
& ACOUSTICS

The rethinking of the traditional workplace is on fast forward. Breakout spaces which offer flow from one place to another, and from one workstyle to another, have never been more relevant. In the world we are now living in, the workplace must provide spaces for work and non-work activities, which encourage employees to come to work to engage, collaborate and thrive. Spaces with a flexible approach that adapts to all needs of the workday.

Fortunately, that is what we do. Multipurpose furniture solutions.

Breakout spaces used to be seen as secondary and alternative settings in the workplace, but we believe today's break-out spaces are just as important as desk sitting spaces. Focusing on breakout spaces as social spaces and as a vital tool in supporting the natural flexing of staff members coming in and out of the office, is key. Breakout areas should be made primary if you ask us: We call them In-between Spaces.

# Rethinking In-Between Spaces

We all know the design and layout of a space, and the surroundings we work in can affect the way we feel. The science of environmental psychology focuses on this very subject, such is its importance.

Rooms facilitate all types of activity, they are not just spaces or the outward face of the organisation. We see rooms as multi-functional spaces where work colleagues collaborate, socialise, learn, and share knowledge. Research suggests that employees only spend on average 30-55% of their time at work by themselves at their desk daily. The rest of the time is spent either out of the house, in meetings, or working together away from the desk with an increased amount of time also spent working from home. Now more than ever, private spaces and traditional desk settings within the office are undergoing significant change.

Whereas breakout and in-between spaces have been regarded as alternative settings as opposed to primary locations (the desk), we argue these spaces are increasingly becoming an essential luxury forming part of a hybrid style of working. In-between spaces have moved up the priority list when designing and planning workspaces.

*Source: (Rum i arbejde - Andersen & Christensen; 2015: 11-15)*



## IN-BETWEEN SPACES



## DESK SPACE







# WELCOME

**WELCOME** /'wel.kəm/ *verb*

- 1. to be pleased about and encourage or support something**
- 2. to meet and speak to someone in a friendly way when they arrive**

We all know first impressions count. Those make or break first impressions in organisations are important. Let the entrance space permeate your brand identity. Do so with warm and inviting soft seating which underpins the very core of your brand. Whether the message is innovation, community, or creativity make sure the area says: Welcome!









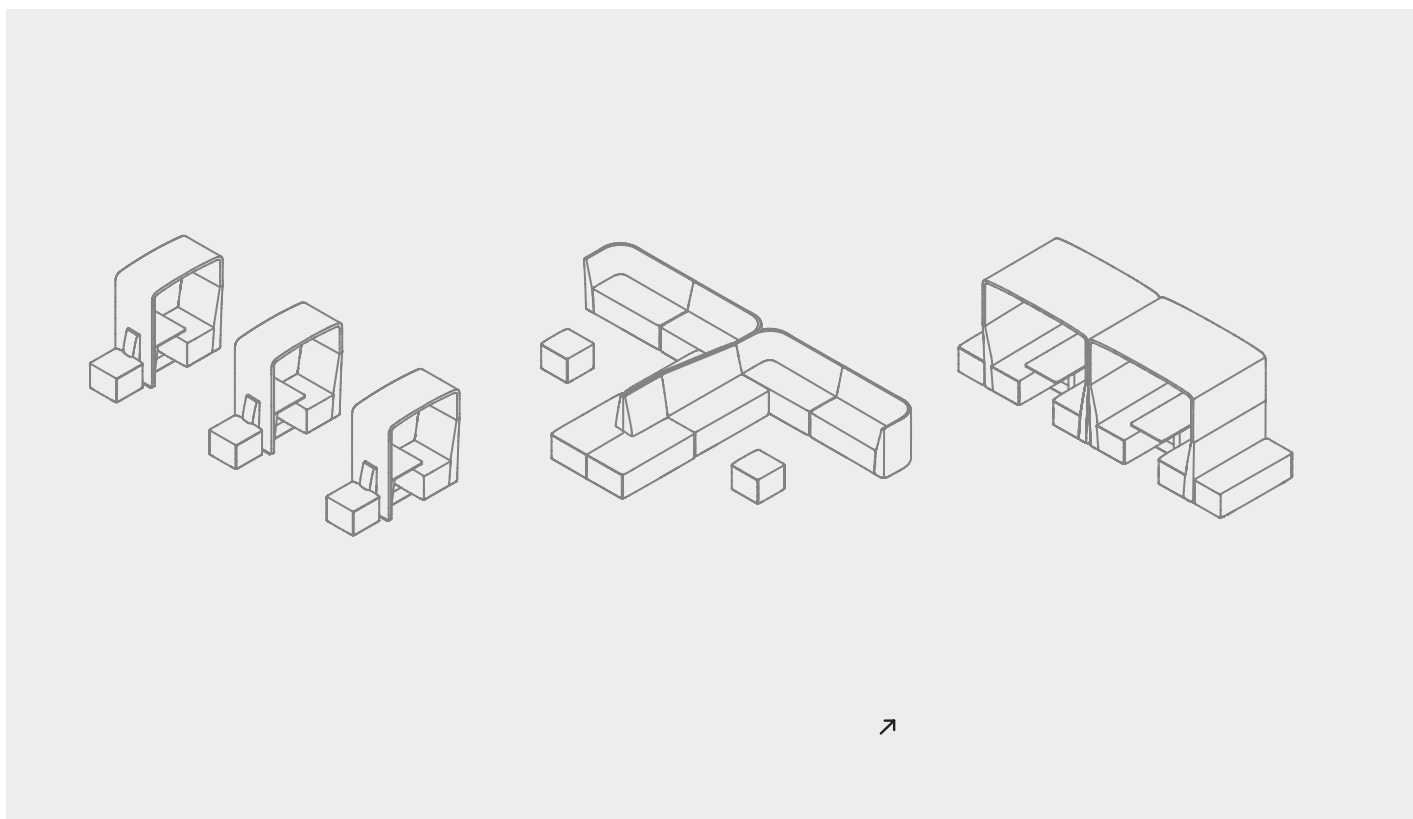

## Warm, cosy and inviting soft seating with modular creativity: What is not to like?



Four® Resting / Design: Strand+Hvass

### The FourLikes® Family

- Highly customisable modular system with linking options
- Compact footprint for utilisation of all square metres
- Efficient seating layout with ideal working heights
- Offers private working spot with acoustic & visual privacy
- Acoustic improving surfaces
- Ingenious styling and curvy organic shapes enhance space perception
- Power and data pass-through options





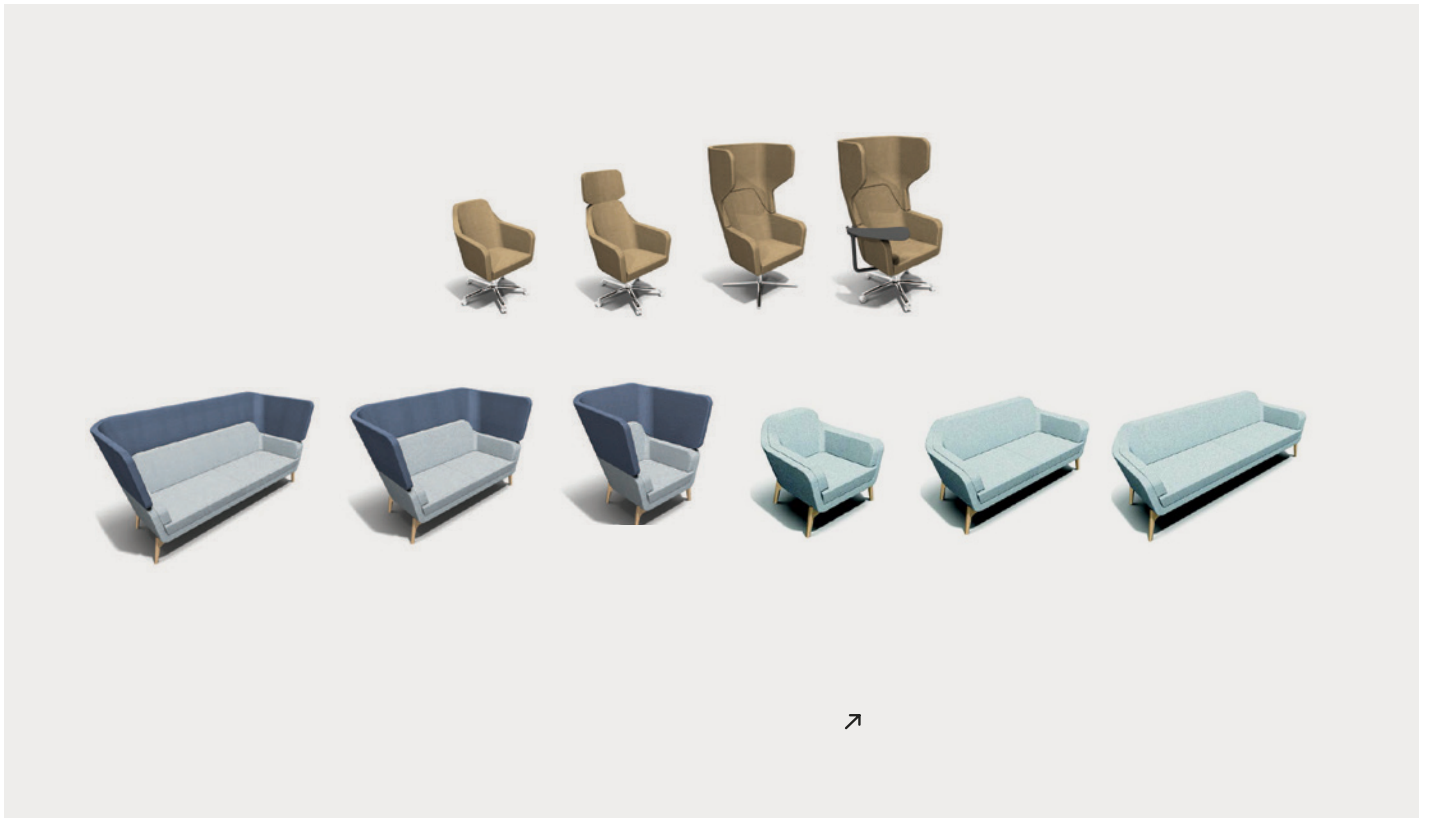

## Say Welcome with a Wow!

In front of house areas the Harc range provides a soft space for social interaction, meetings and a place of refuge to cut out or reduce the surrounding noise. Within busy workplaces and collaborative environments, there is a need for furniture that encourages social interaction, intimate meeting places, privacy, and places of refuge where focus, paying attention and listening are essential.



### Harc Family

- Low & acoustic high back lounge and meeting chairs
- Upholstery by choice available in fabric, vinyl or leather
- Moulded foam for additional comfort and durability
- Chrome wire frame base and wooden base in oak & black ash as standard with other options on request or polished aluminium swivel base with tilt & optional return function
- Powder coating available in silver, black & white – or others on request
- Optional Inno<sup>®</sup>Tab









## Saying welcome in relaxed surroundings

... Can make a world of difference. Muted colours and soft comfortable furniture can impact the way visiting or waiting guests feel. And it is all about making them feel safe and comfortable. Billo ticks all the boxes and has all those qualities which will make your customer, client or visitor feel both welcome and comfortable.

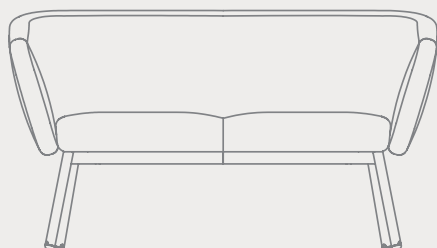

Explore Billo:



Billo w. wooden legs



## How to make a first great impression? Well, we believe Skyline has the answer!

### **Skyline**

- 22 modular units for multiple configurations
- Matching coffee tables with different table top options
- Two-tone fabric options
- Powder coated leg options
- Split back option available on request
- Power and data available
- Fully webbed seat for optimum comfort









# LOUNGE

**LOUNGE** /laʊndʒ/ *noun*

- 1. a public room for relaxing or waiting in**
- 2. a room in a hotel, airport, theatre, etc. where people can relax or wait**

/laʊndʒ/ *verb*

- 1. to stand or sit in a relaxed way**

In a world where we are constantly referring to experiences, the in-between space is most likely to deliver a valuable experience. Relaxing alternatives to desk seating in the office and social spaces are effective in breaking down silos within organisations. They encourage community and collaboration. And that is what we want.











**Ideal for the built environment and scooting around in the open space. Comfortable as seating too, even in the meeting room.**

## FourLikes® Family

Modules in this collection include Sofas with different back options, freestanding Scooter Benches and modules, the infamous Meet module and a wall-mounted bench.

Whether it is a modern working environment, break-out area or reception, this system has been designed for the needs of today. You can customise and add personality to suit your work needs and culture. Styling and modular creativity? We will leave it up to your imagination.



FourLikes® Scooter 90 / Design: Nørgaard Design



Touch Bench / Design: David Fox

## Create interesting and engaging spaces for those informal meetings. Variation is key.

### FourMe®

- Endless possibilities for seat-, full- and innerside upholstery
- Biocomposite shell
- Swivel with freefloat in seat/back
- Optional Return mechanism
- Polyamide glides as standard
- Teflon or felt glides and soft castor options
- Powder coated frame options

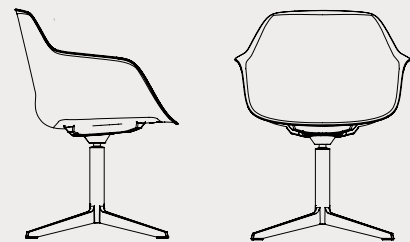



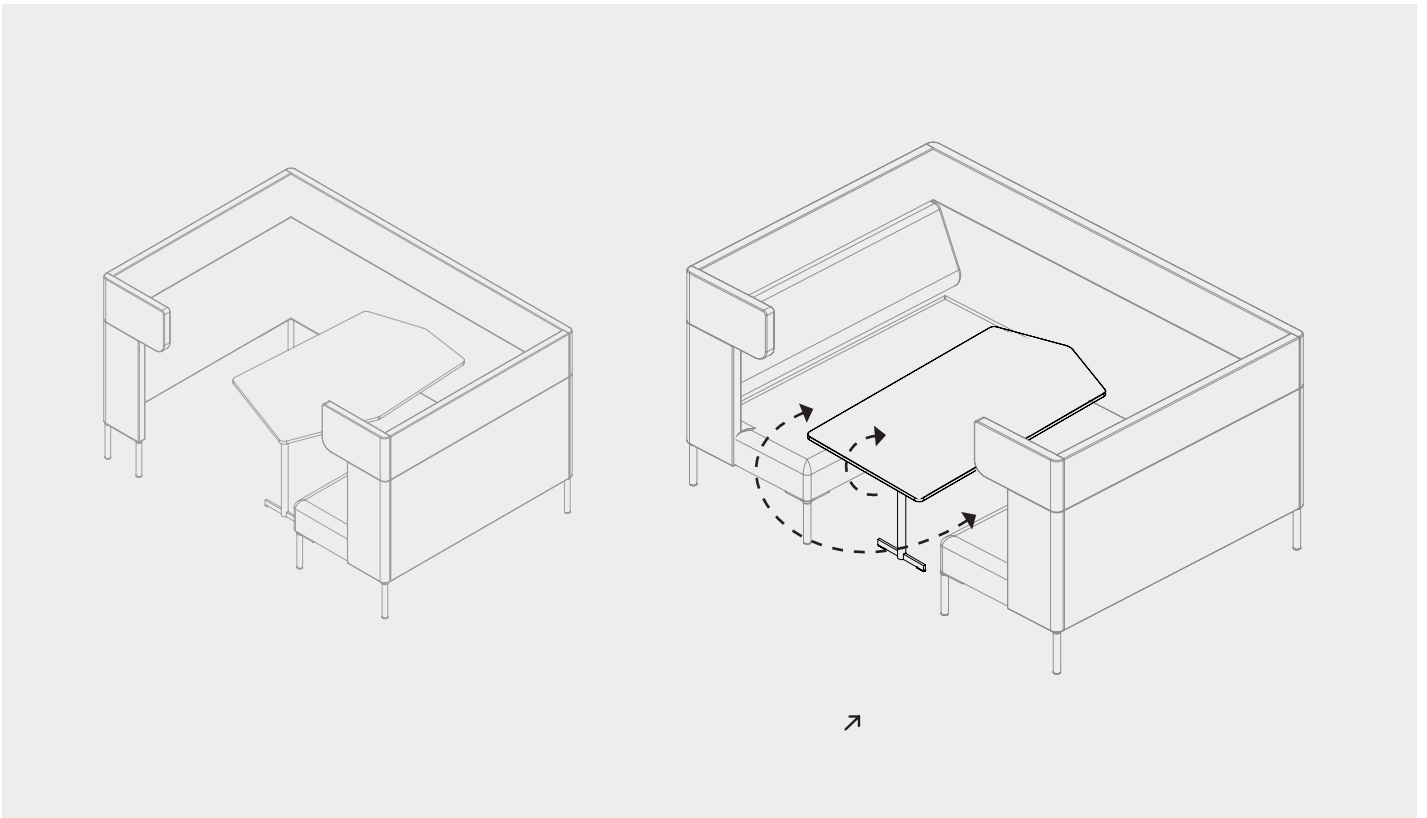

## Tech Savvy and Comfortable

Create acoustic and visual privacy with the FourUs® Booth. The booth creates a comfortable spot for people to meet undisturbed for an informal talk or a coffee break. Data or power options enable visitors to make those last presentation amendments and employees can create a change in tempo before the next client. Simply because the acoustic features are superb!



### FourUs® Booth

- Part of extensive modular system
- Compact footprint
- Efficient seating layout with ideal working height
- Private working areas with acoustic and visual privacy
- Facility friendly; designed for optimised cleaning
- Endless upholstery options
- Power and data options
- Pivoting table that effortlessly moves both horizontally and vertically













## A Stylish Staff Break out

A warm and welcoming space for employees to meet, lounge and talk about nothing in particular, is vital. The staff break out area, along with the canteen, is the heart of the office. This is where trust, community and a sense of belonging emerge as the glue that keeps the business growing.

### Dapper Dishy

The Dishy chair and sofa offer a stylish solution to any environment. High or low-backed lounge chairs boast a selection of bases from the wooden frame, to swivel or four-legged bases in chrome and powder coated steel.

The generous seat and premium quality foam provide a high level of comfort.

Dishy offers a round top, four-star base and two four-legged oval tables with either wood, chrome or white powder coated legs.



Dishy Chair w. wooden legs



Case: BGF, London - Race Heritage Furniture / Design: Ernest Race





Alfi

**Juxtaposing textures, contrasting colours and a mix of furniture. An eclectic style creates warmth and personality to the space. Mix then and now.**

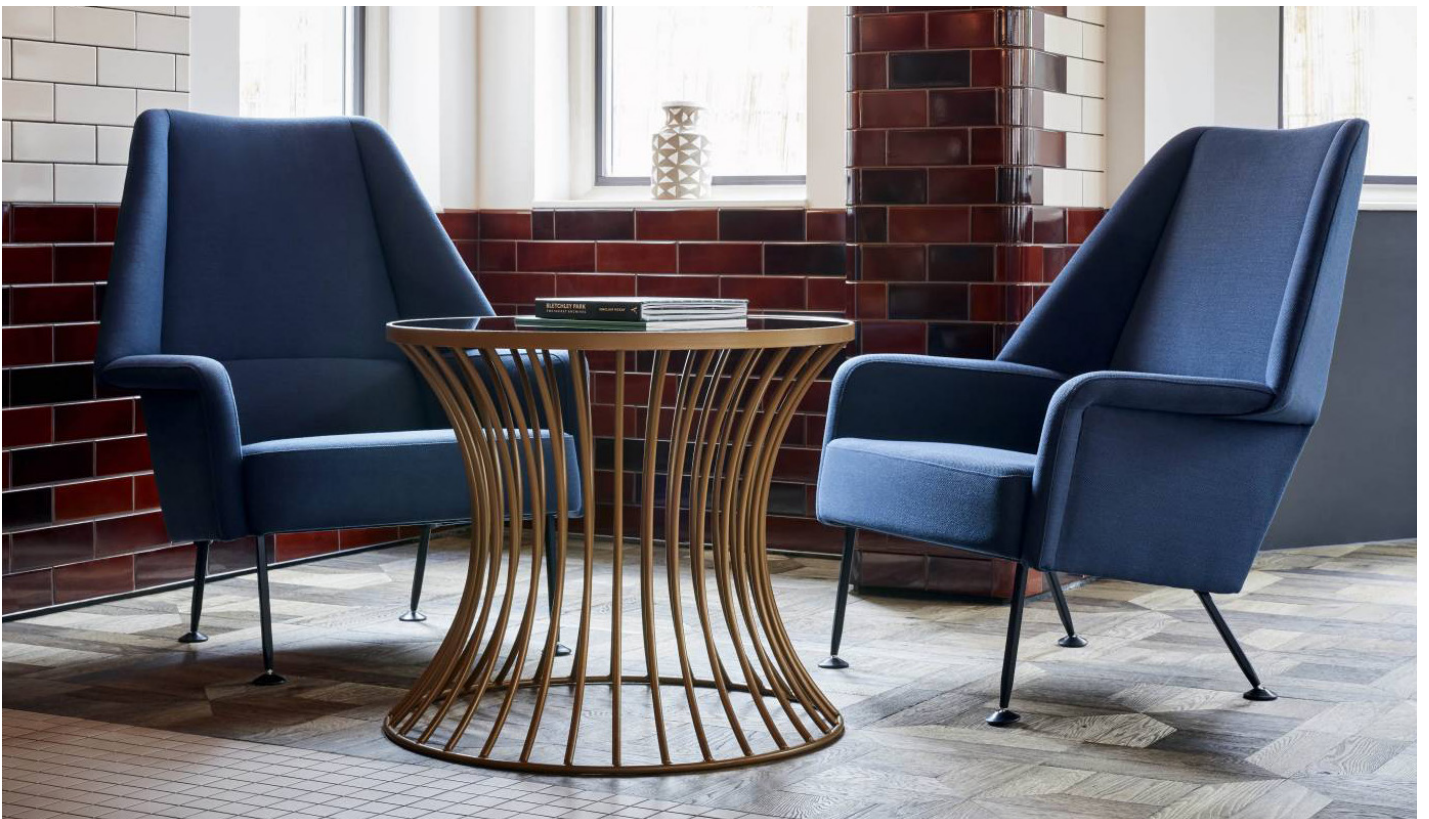

Flamingo / Design: Ernest Race





# IMPROMPTU

**IMPROMPTU** /im'promp.tfu:/ *Adjective*

**1. done or said without earlier planning or preparation**

Essentially, we are humans. And we want to be together, even if we are looking for somewhere to get our head down and concentrate. Create spaces which enable engaging and maintaining relationships, the culture, and feel-good-factor of a team working together, because this will become more and more important.









Four® Stools + Four® Seating Benches / Design: Strand + Hvass

## Great for Chance Encounters

The FourReal® A table is a real conversation starter. This solution is the perfect fit for collaborative work or head-down work. It works perfectly as a communal area, for eating, or meetings. Or those in-between conversations.



Four® Stools w. upholstery / Strand + Hvass

### FourReal® A

- Various heights and dimensions available
- Accessories & options for you to add biophilia and a personal touch
- Cable pass through option
- Matches FourReal® family of tables

### Four® Stools & Four® Seating Benches

- Various heights available for stools matching our other chair and table ranges
- Highly customisable, with various seat/ upholstery, base & finish options
- Works with chair suspension feature



FourUs® Worx

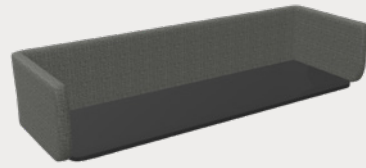

FourUs® WallPod

**Head down. Tune in. Get those fire cracking ideas going. Or get up to speed with everything.**

## Furniture that works

The FourUs® Worx has been created by award-winning designer Anders Nørgaard.

It is visionary, modern and it provides a flexible and dynamic solution that invites you in. The clean Scandinavian design can be showcased in a wide variety of fabric combinations.

Perfect for a break out or in-between area.



FourUs® Worx / Design: Nørgaard Design









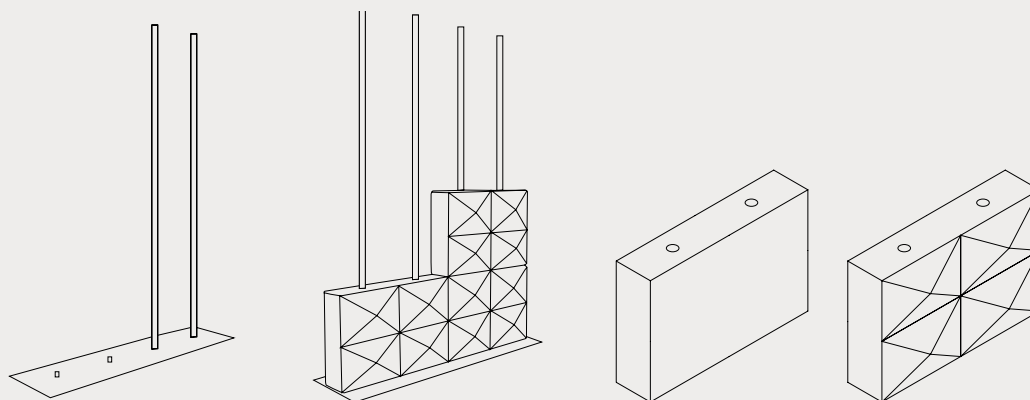

Learn more:

## In between focus and activity

Space divide with a wall of Fabricks™. They are super acoustic bricks made from acoustic foam and wool fabric. Designed to look fabulous, they provide a space to do group work, brainstorm or just hold a brief meeting away from the hubbub of the office. Quickly configured and reconfigured, Fabricks™ offer the flexibility to change spaces in the modern open plan workplace, the dynamic of a space and even the location of power can be altered in moments.



### Fabricks™

- Reduced dilapidation costs
- Easy to reconfigure
- 2D flat face and 3D sculptured face lightweight bricks in 3 different lengths (30 cm, 60 cm or 120 cm), 2 different heights (20 cm or 40 cm)
- Tested to ISO 10053 and BS EN ISO354:2003
- Class A sound absorption according to BS EN ISO 11654
- Minimum of 95% recyclable

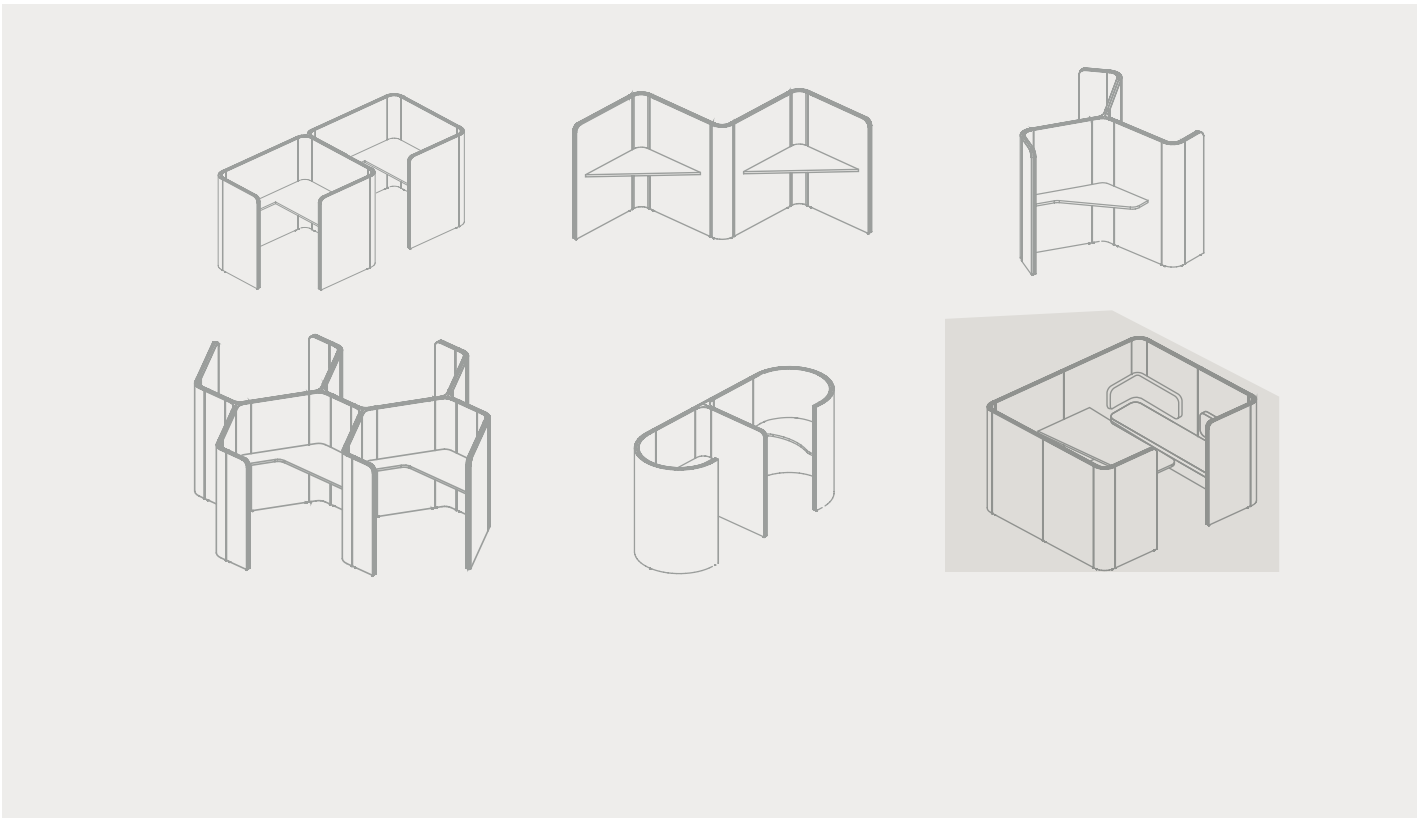

## Do you remember making a Den?

Den is your noise barrier, acoustically enhanced to separate you from the hubbub of the workplace. Den can have power, reading lights and data connectivity. Worktops can be positioned to suit your working style, and soft seating can make your Den a comfortable retreat.

## Den Landscape

Den is a range of acoustic work areas created to make public spaces private. Den facilitates heads down work and spaces for lively collaboration and knowledge sharing.

But what happens when you need a restful place? Den reduces visual and acoustic distraction; it is about creating the most effective environment for you to work happily and efficiently.













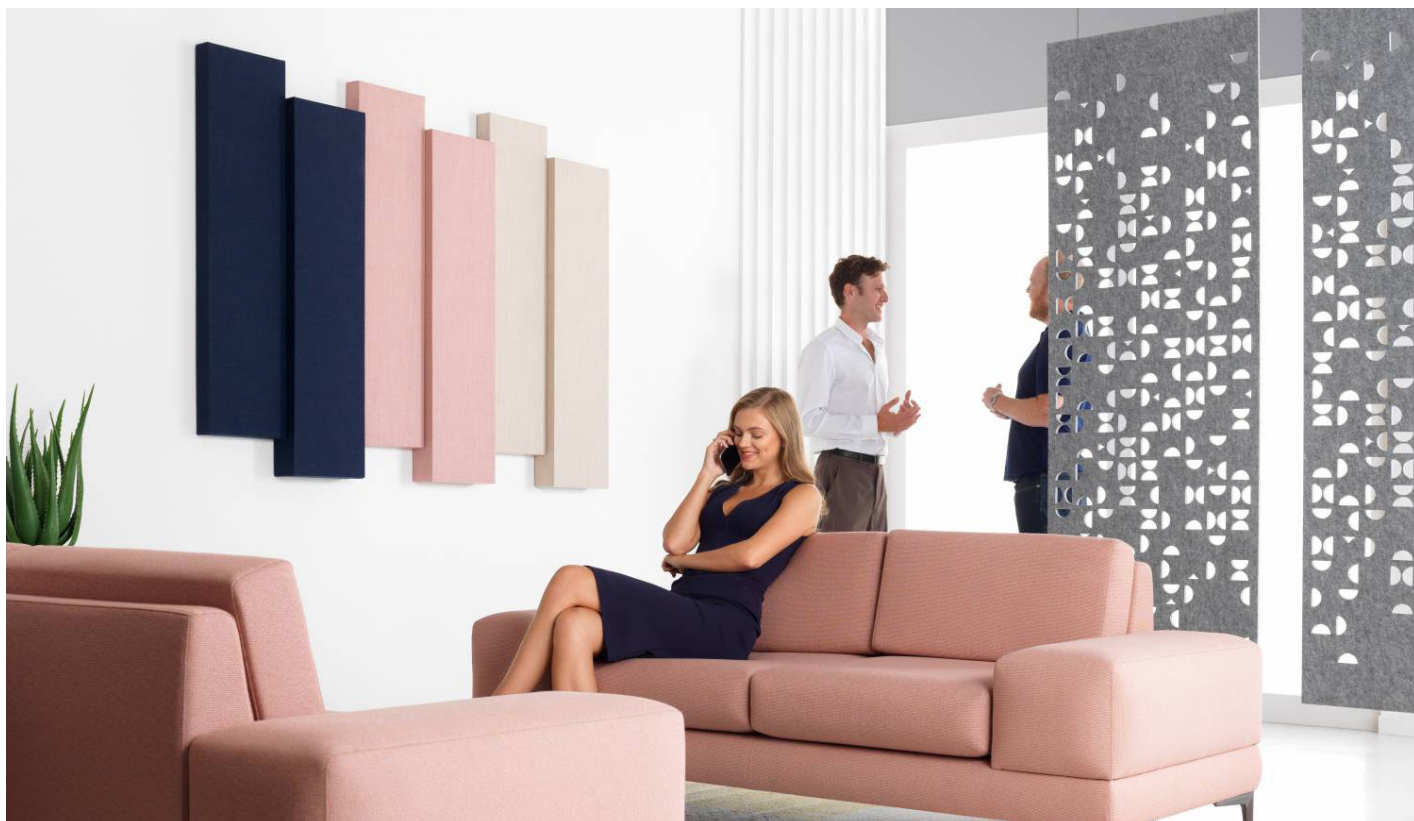

Tessellate Sound Panel + Puzzle Panels

## Bring down the noise without putting a dampener on the conversation...

### Stylish Sound Absorption

Create your own acoustic configuration with the Sound Tessellate collection. With seven shapes, different depth options and extensive fabric and colour choices, Positive Sound Tessellate is a bright and flexible acoustic panel system.

The Tessellate acoustic panels have been tested to Class A absorption, meaning they are highly efficient at absorbing sound across a wide range of frequencies.



Tessellate Sound Panel

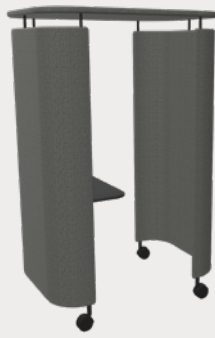

InnoPod®



InnoPod® Big



**Take your workspace for a spin.  
Meet up with peers for a side by side collab  
or retreat to your own space.**

## A Soundproof Space

Fitted with large castors, you can spin the InnoPod® round to create a barrier against the visual and acoustic distraction; you can even quickly change the desk height to your desired working style. The InnoPod® is perfect for in-between spaces, atriums, or anywhere you need a touchdown space. The InnoPods can also be used together in hallways to create banks of flexible study areas because they only take up about one m<sup>2</sup>.

### InnoPod®

- Super agile work pod for one person
- Fantastic sound absorbing properties thanks to foam and upholstery
- Two different working heights
- Chair suspension option

### InnoPod® Big

- The highly agile InnoPod® Big serves as a comfy work space for one to 4 persons
- Two different working heights
- Chair suspension







# PAUSE

**PAUSE** /pə:z/ *noun*

**a short period in which something such as a sound or an activity is stopped before starting again**

Offer a pause in movement. Before the next meeting or before welcoming your next client. Soft furniture connected by the scent of really nice coffee, books or a chance encounter with a colleague create those markers in routine which are vital for a thriving culture. A pause in movement allows a given space to become a center of felt value. Front and back of house.





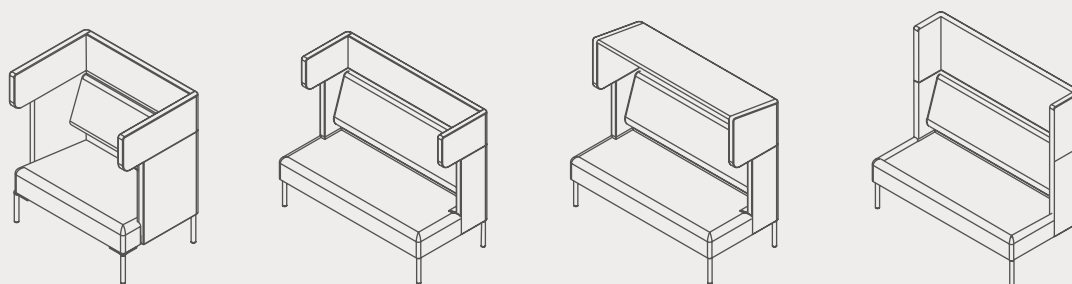

## A Periphery Pause

When about to reach your limit: Enter: books, a report or a white paper. Reading works as a stress reducer and paired with a nice cup of coffee, a few minutes is all it takes for your brain to recharge.

### FourUs® Family

- Modular zoning range with two & three seater sofas, single seating & booth options + freestanding and wall based units
- Efficient seating layout with ideal working height
- Offers private working area with acoustic & visual privacy
- Wide range of base, finish & accessory options
- Pivoting table & Inno®Tab option
- Power & data options
- Designed for compact footprint
- Facility friendly
- Castor options



FourUs® Solo with castors / Design: Nørgaard Design

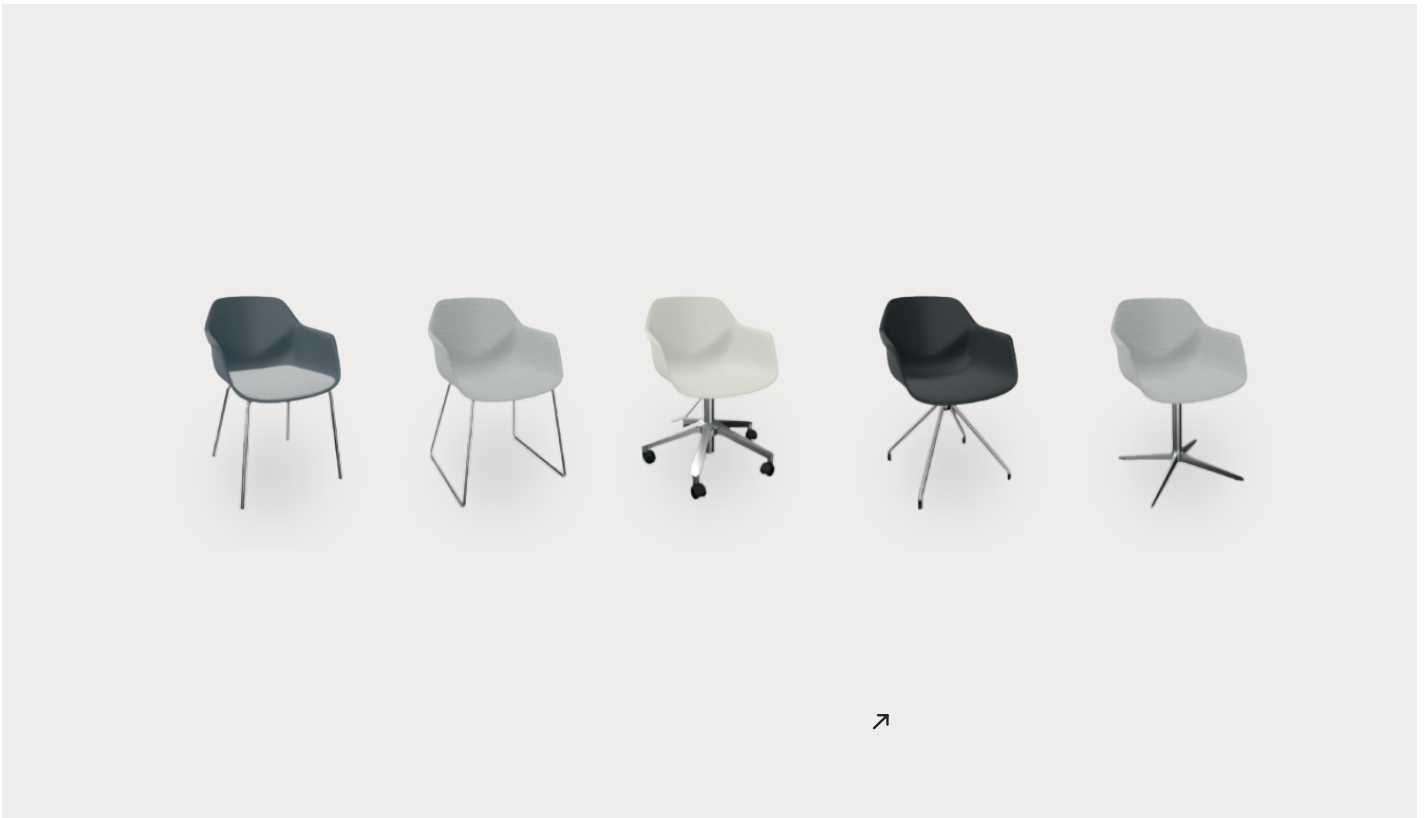

**Break away to a quiet space for a collaboration, a 1:1 conversation or an online meeting.**



#### **FourMe®**

- Endless possibilities for seat-, full- and innerside upholstery
- Biocomposite shell
- Swivel with freefloat in seat/back
- Optional Return mechanism
- Polyamide glides as standard
- Teflon or felt glides and soft castor options
- Powder coated frame options

#### **Inno® Tab**

- Integrated smart-triggered cup holder + easy flip-top function
- Efficient & space saving dimensions (52×32 cm)

Inno® Tab with integrated cupholder





**A strong community feeling is key. A space for employees to feel welcomed, appreciated and safe, is the way forward...**

**FourSure® 90/105 Eco**

- Complies with strict criteria set by the Environment Directorate General of the European Commission

**The EU Ecolabel guarantee:**

- Limitation of substances harmful to health and the environment
- Design for higher product durability and easy disassembly
- Recycled packaging prioritised
- Only FourSure® 90/105 in Ebony Black shell with black or anthracite legs are granted with EU Ecolabel

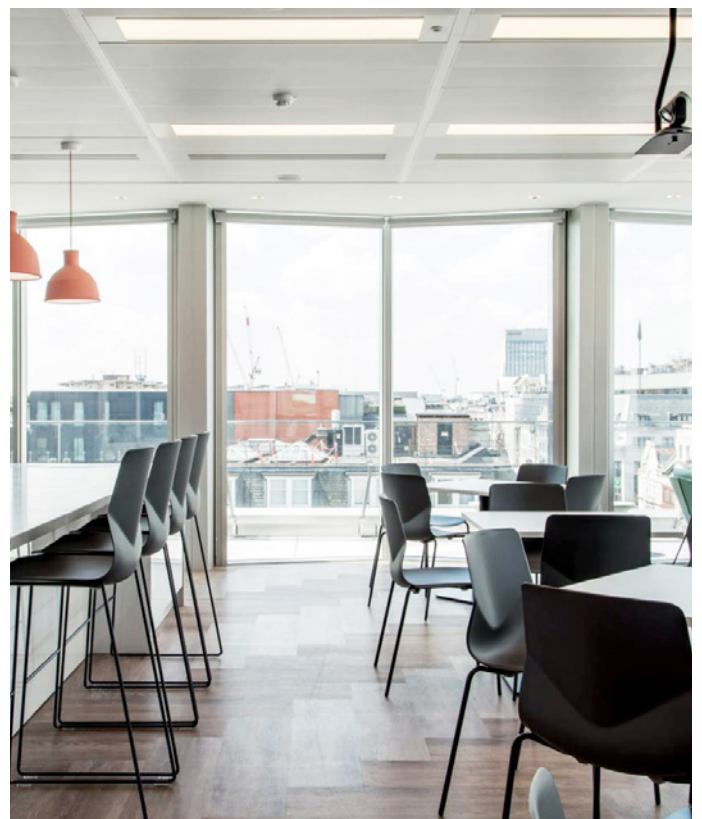







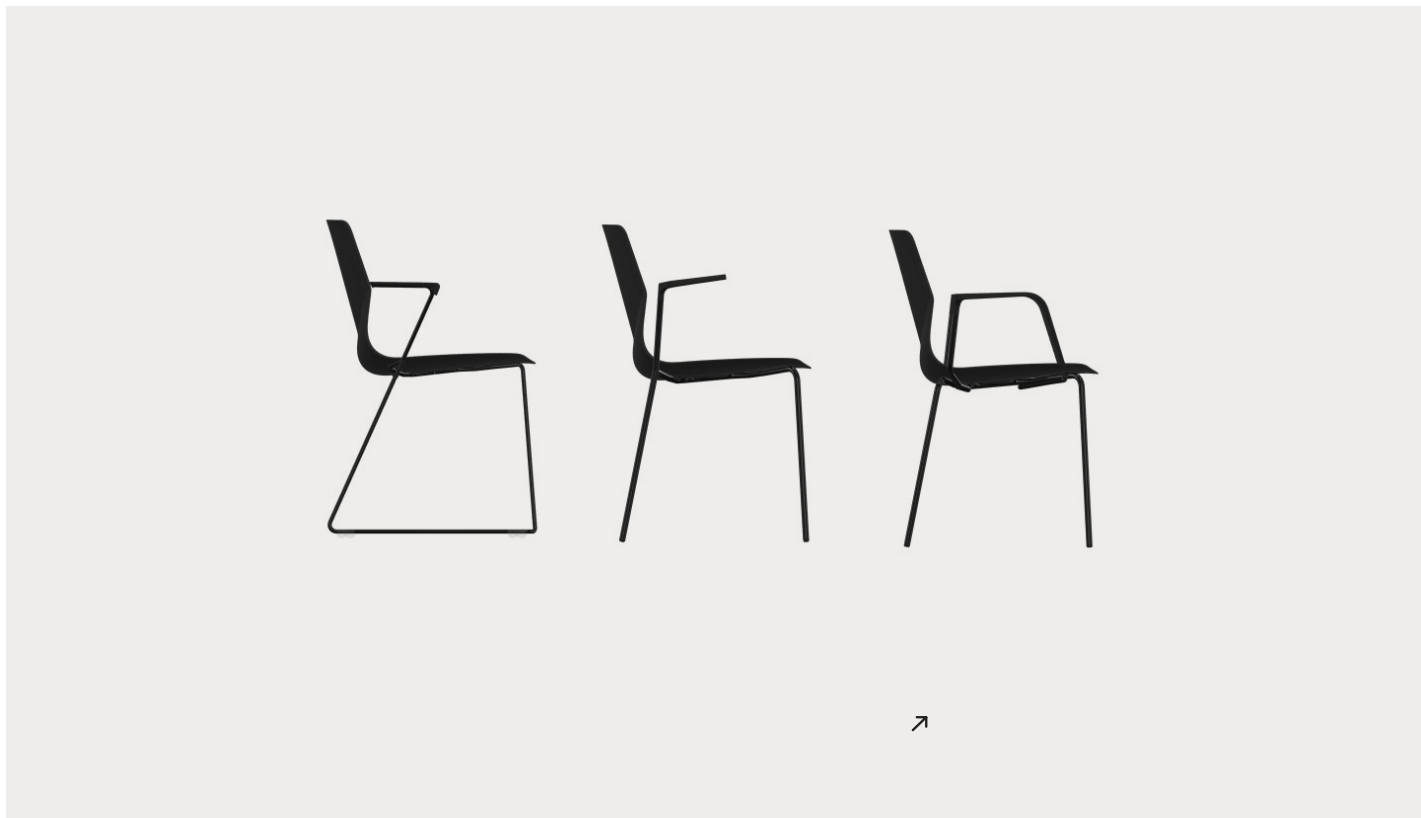

## Break out of the Norm

The centre of a space is public. The periphery is for interaction amongst work peers. A well thought out in-between space should offer the opportunity for both types of interaction. For that you need flexibility and movability in your design solutions. Whether it is to work, socialise or just simply pause.



### FourSure® 77

- Stacking chair on castors
- Ergonomic comfort
- Available w. seat pad, innerside or fully upholstered
- Flexible and movable
- Armrest option for easy handling and comfort

FourSure® 77 w. armrest / Design: Strand+Hvass

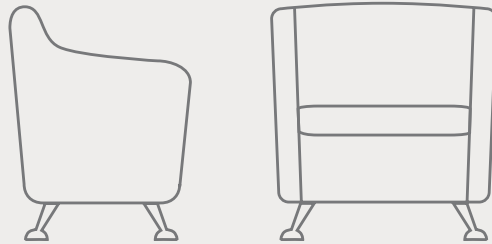

## Comfortable and welcoming

Combining a generously proportioned seat with a compact overall footprint, our exclusive Solace range is the versatile seating solution for confined spaces. Exceptionally comfortable, the stylish tub design can be finished with ball foot brushed chrome or sleek polished chrome legs. Striking two-tone fabric options perfectly complement the design. Perfect for any waiting area or reception or a pause before welcoming your next client.

### **Solace**

- Tub chair with compact footprint and generously proportioned seat
- Available in fabric and vinyl, with two tone options
- Ball foot brushed chrome and polished chrome leg options
- CMHR foam

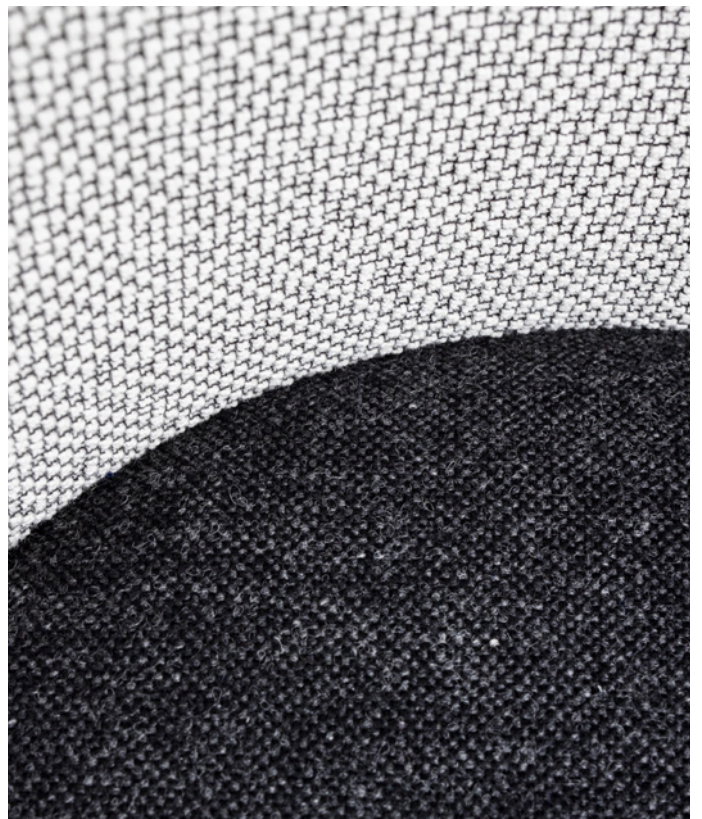

Two tone upholstery option





FourSure® 77  
P. 60-62



FourSure® 44  
P. 36, 41, 48



FourMe®  
P. 24-25, 42-43, 58-59



Stools & Benches  
P. 38-39



Harc range  
P. 10-12, 54-55



Alfi  
P. 34



Strech  
P. 35

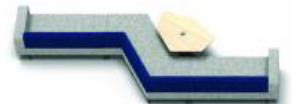

Skyline  
P. 16-17



Billo  
P. 14-15



Dishy  
P. 18-19, 30-31



Solace  
P. 64-65



FourUs® Booth  
P. 26-29



FourUs® Solo  
P. 56-57



FourLikes®  
P. 6-9, 20-23



InnoPod®  
P. 52-53



FourReal® Tables  
P. 42-43, 48, 62



FourReal® A  
P. 36-39



FourUs® Worx  
P. 40-42

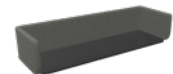

FourUs® Wallpod  
P. 40, 49

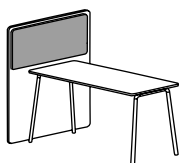

RoomInRoom  
P. 42-43, 48-49



Den  
P. 46-47

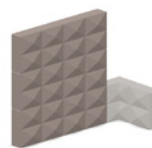

Fabricks™  
P. 44-45

# A Unique Design Philosophy

Function. Design. Aha. Inextricably intertwined with one another, you hear us talk about it a lot. Basically, FDA is our way of spelling out exactly what we think design should be all about.

We talk about FDA perpetually because we are very adamant about it. It is the backbone of our approach to the way we do things and serves as a succinct summary of our vision, product strategy, and goals. It's our design philosophy. That something special. The added value.

But it is so much more than that. It is a way of life. It is not rocket science. Let's break it down.

## **Function**

Does it save m<sup>2</sup> in the most intelligent way possible? Is it task aware? Does it provide visual or acoustic privacy? Does it have comfort? Does it have modularity?

## **Design**

Does it have visual appeal? Is it easy on the eye? Does it tickle our senses? Is it compatible with our other furniture concepts? Are we taking care of our planet?

## **Aha**

Is there an element of surprise? Does it prompt inner smiles? Does it have a unique intangible quality? Does it have value for money?

These are just some of the questions that we ask ourselves when developing those really fresh ideas. If we can't answer an obvious yes... we push ourselves further.

Because we are driven by happy people, inspiring environments and a deeper sense of purpose.



To discuss a project or to view the range contact:

[interiors@quillsuk.co.uk](mailto:interiors@quillsuk.co.uk)  
[Quillsinteriors.co.uk](http://Quillsinteriors.co.uk)  
0845 078 0324