



QUILLS GROUP
■■■■■■■■ OFFICE INTERIORS

Four[®]Us

Designed by Anders Norgaard



Features

- Designed by Anders Nørgaard
- Modular zoning system
- Freestanding and wall based units
- Nano laminate 21mm table tops with impact resistant ABS edges
- Standard leg frame black RAL (7021) other colours available on request

- Optional linking device, castors and wooden legs
- Optional shelf in nano laminate for back of Four®US freestanding units
- Available with Inno®Tab writing tablet

 58kg
FUB/EA

other weights on application

 Min 95% recyclable



Inspiration - Four[®]Us Sofas

QUILLS GROUP
OFFICE INTERIORS

Dimensions (mm)

Four®US Bench

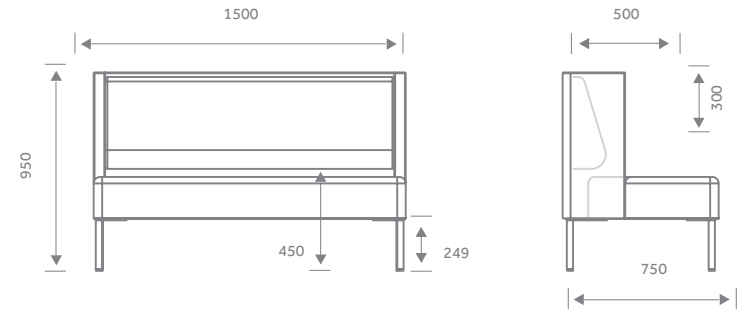

Four®US Bench with Extension

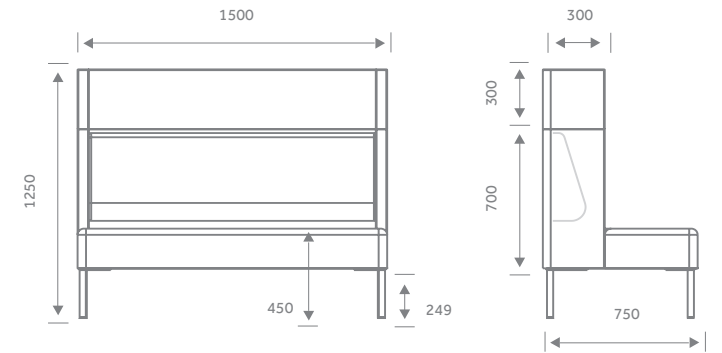

Four®US Bench with Ears

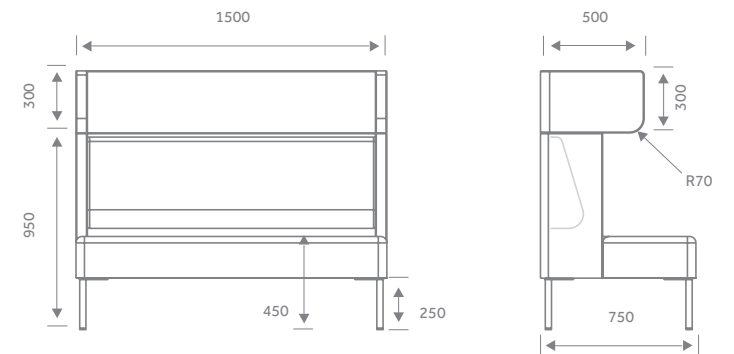

Layouts

Dimensions (mm)

Four®US Bench with Cave

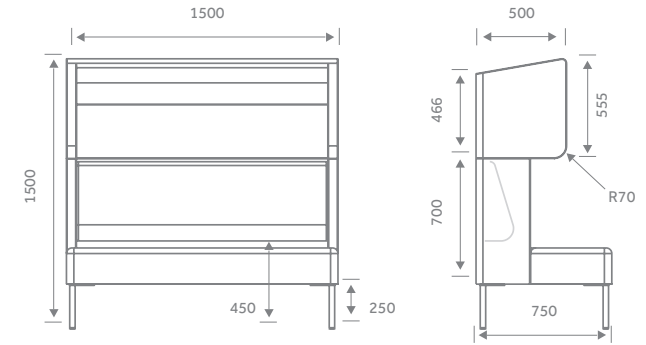

Four®US Booth

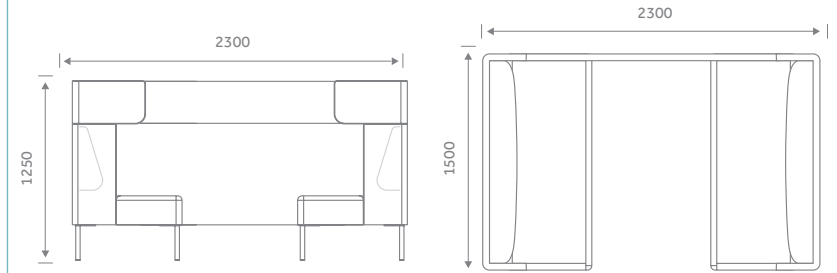

Four®US Long & Short Stool



Layouts



Dimensions (mm)

**Four®US Booth
with Pivot Table**

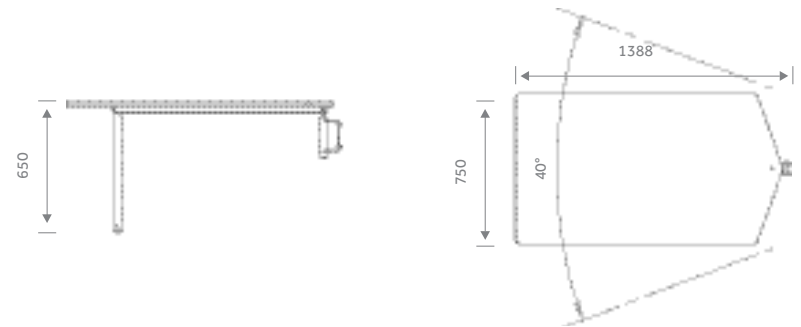

Four®Us Booth & Pivot Table



Available with Castors & Wooden legs as an option



Available with Inno® tab and shelf



Four® Us Options

QUILLS GROUP
■■■■■■■■ OFFICE INTERIORS



Inspiration - Four[®]Us Wall

QUILLS GROUP
■■■■■■■■ OFFICE INTERIORS

Four®US Wall



Dimensions (mm)

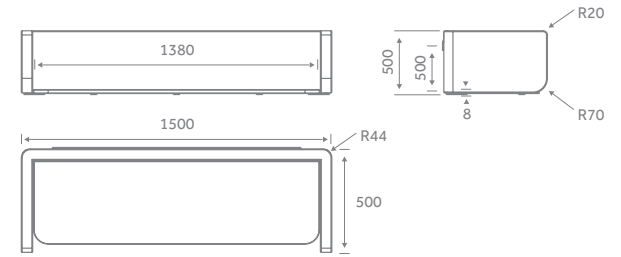

Four®US Wall Cave

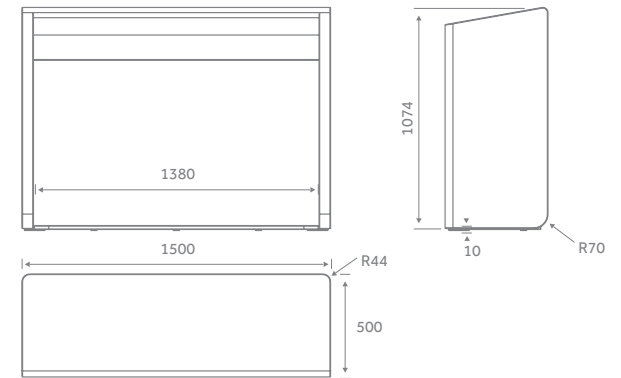



Quills Interiors
Unit 2 Spitfire Business Park
1 Hawker Road
Croydon
Surrey
CR0 4WD

London Showroom
20 Old Street
Clerkenwell
London,
EC1V 9AB

t. 0845 078 0324
e: interiors@quillsuk.co.uk
w: quillsinteriors.co.uk